

ASTM C-450

Short Radius Ells - Recommended Dimensional Standards

Pipe Size	Insulation Thickness																			
	1"					1 1/2"					2"					2 1/2"				
	A	B	C	D	E	A	B	C	D	E	A	B	C	D	E	A	B	C	D	E
1	4	1 3/32	*	0.58	2	4	1 3/16	*	0.64	2 3/16	4	1 1/2	*	0.84	2 23/32	4	1 11/16	*	0.97	3 3/32
1 1/4	4	1 3/16	*	0.55	1 27/32	4	1 15/32	*	0.74	2 11/32	4	1 19/32	*	0.81	2 17/32	4	1 13/16	*	0.94	2 29/32
1 1/2	4	1 3/8	*	0.58	1 27/32	4	1 9/16	*	0.71	2 3/16	4	1 29/32	*	0.91	2 3/4	4	2 3/32	*	1.03	3 3/32
2	4	1 9/16	*	0.53	1 1/2	4	1 7/8	*	0.72	2 1/32	4	2 3/32	*	0.85	2 13/32	4	2 9/32	*	0.98	2 3/4
2 1/2	4	1 31/32	*	0.59	1 1/2	4	2 9/32	*	0.79	2 1/16	4	2 1/2	*	0.92	2 13/32	4	2 11/16	*	1.04	2 3/4
3	4	2 9/32	1/16	0.41		4	2 1/2	*	0.74	1 11/16	4	2 11/16	*	0.86	2 1/16	4	2 29/32	*	0.98	2 13/32
3 1/2	4	2 11/16	1/16	0.47		4	2 29/32	*	0.80	1 11/16	4	3 3/32	*	0.93	2 1/16	6	2 3/16	*	1.05	2 13/32
4	4	2 29/32	1/4	0.54		4	3 3/32	1/16	0.54		6	2 3/16	*	0.87	1 23/32	6	2 5/16	*	0.99	2 1/16
4 1/2	4	3 3/32	1/16	0.54		6	2 3/16	*	0.87	1 23/32	6	2 5/16	*	0.99	2 1/16	6	2 7/16	*	1.13	2 7/16
5	6	2 5/16	9/32	0.67		6	2 7/16	5/32	0.67		6	2 9/16	1/32	0.67		6	2 23/32	*	1.02	1 3/4
6	6	2 11/16	7/16	0.80		6	2 27/32	9/32	0.80		6	2 31/32	5/32	0.81		6	3 1/8	1/32	0.81	
7	6	2 27/32	9/32	0.80		6	2 31/32	5/32	0.81		6	3 1/8	1/32	0.81		6	3 1/4	*	1.15	1 3/4
8	6	3 1/2	21/32	1.07		6	3 5/8	17/32	1.07		6	3 25/32	13/32	1.07		6	3 15/16	1/4	1.07	
9						6	3 25/32	13/32	1.07		6	3 15/16	1/4	1.07		6	4 1/16	1/8	1.07	
10						6	4 15/32	25/32	1.33		6	4 19/32	5/8	1.33		6	4 23/32	1/2	1.33	
11						6	4 19/32	5/8	1.33		6	4 23/32	1/2	1.33		8	3 5/8	9/32	1.33	
12						8	3 15/16	25/32	1.60		8	4 1/32	21/32	1.60		8	4 1/8	9/16	1.60	
14						8	4 13/32	1 1/16	1.86		8	4 1/2	31/32	1.86		8	4 5/8	7/8	1.86	
15						8	4 1/2	31/32	1.86		8	4 5/8	7/8	1.86		8	4 23/32	25/32	1.86	
16						8	5	1 1/4	2.12		8	5 3/32	1 5/32	2.12		8	5 7/32	1 1/16	2.12	
17						8	5 3/32	1 5/32	2.12		8	5 7/32	1 1/16	2.12		8	5 5/16	31/32	2.12	
18						8	5 19/32	1 15/32	2.38		8	5 11/16	1 11/32	2.38		8	5 25/32	1 1/4	2.38	
19						8	5 29/32	1 9/16	2.51		8	5 25/32	1 1/4	2.38		8	5 29/32	1 5/32	2.38	
20						8	6 3/16	1 21/32	2.64		8	6 9/32	1 9/16	2.64		10	5 3/32	1 5/32	2.65	
21						10	5 3/16	1 13/32	2.78		10	5 3/32	1 5/32	2.65		10	5 3/16	1 3/32	2.65	
22						10	5 13/32	1 15/32	2.91		10	5 1/2	1 13/32	2.91		10	5 9/16	1 5/16	2.91	
23						10	5 21/32	1 9/16	3.04		10	5 9/16	1 5/16	2.91		10	5 21/32	1 1/4	2.91	
24						10	5 7/8	1 5/8	3.17		10	5 31/32	1 9/16	3.17		10	6 1/32	1 15/32	3.17	

- A = Minimum Number of Miters for 90° Ell, use half for 45° Ell
- B = Miter Base Dimension
- C = Miter Top Dimension (* Denotes Negative Radius, See Column E)
- D = Lineal Feet of Pipe Covering for One Fitting Cover
(Based on alternating cuts and allowing for saw kerf and waste)
- E = Tangent Length for Negative Radius Fittings (Figure 2.2)¹

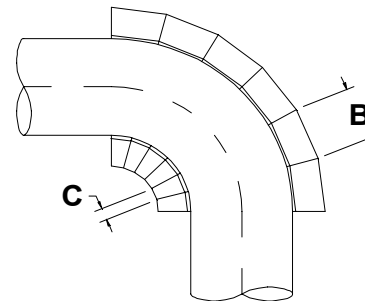

Figure 2.1 Regular Short Radius Ell

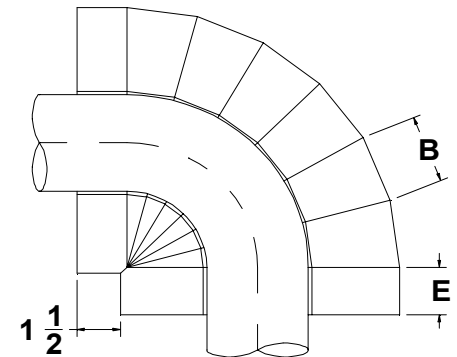

Figure 2.2 Negative Radius Ell

¹ - Mitered Negative Radius Fitting Covers create a 'humped' phenomenon in the throat of the fitting. This 'hump' must be rasped down to ensure proper fit with metal elbow covers.

ASTM C-450

Short Radius Ells - Recommended Dimensional Standards

Insulation Thickness

Pipe Size	3"					3 1/2"					4"					4 1/2"				
	A	B	C	D	E	A	B	C	D	E	A	B	C	D	E	A	B	C	D	E
1	4	1 29/32	*	1.09	3 7/16	4	2 3/32	*	1.22	3 25/32	4	2 9/32	*	1.34	4 1/8	4	2 17/32	*	1.48	4 17/32
1 1/4	4	2	*	1.06	3 1/4	4	2 3/16	*	1.19	3 19/32	4	2 13/32	*	1.31	3 31/32	4	2 5/8	*	1.45	4 11/32
1 1/2	4	2 9/32	*	1.16	3 7/16	4	2 1/2	*	1.28	3 25/32	4	2 23/32	*	1.42	4 5/32	4	2 29/32	*	1.55	4 17/32
2	4	2 1/2	*	1.10	3 3/32	4	2 11/16	*	1.22	3 7/16	4	2 29/32	*	1.36	3 13/16	4	3 1/8	*	1.49	4 5/32
2 1/2	4	2 29/32	*	1.17	3 3/32	4	3 1/8	*	1.31	3 15/32	6	2 3/16	*	1.43	3 27/32	6	2 5/16	*	1.56	4 3/16
3	4	3 3/32	*	1.11	2 3/4	6	2 3/16	*	1.25	3 5/32	6	2 5/16	*	1.38	3 1/2	6	2 7/16	*	1.50	3 27/32
3 1/2	6	2 5/16	*	1.19	2 13/16	6	2 7/16	*	1.32	3 5/32	6	2 19/32	*	1.44	3 1/2	6	2 3/4	*	1.60	3 15/16
4	6	2 7/16	*	1.13	2 7/16	6	2 19/32	*	1.26	2 13/16	6	2 23/32	*	1.38	3 5/32	6	2 7/8	*	1.54	3 19/32
4 1/2	6	2 19/32	*	1.26	2 13/16	6	2 23/32	*	1.38	3 5/32	6	2 7/8	*	1.54	3 19/32	6	3	*	1.66	3 15/16
5	6	2 27/32	*	1.14	2 3/32	6	2 31/32	*	1.27	2 7/16	6	3 5/32	*	1.42	2 7/8	6	3 9/32	*	1.55	3 1/4
6	6	3 1/4	*	1.15	1 3/4	6	3 13/32	*	1.30	2 3/16	6	3 17/32	*	1.43	2 17/32	6	3 21/32	*	1.55	2 7/8
7	6	3 13/32	*	1.30	2 3/16	6	3 17/32	*	1.43	2 17/32	6	3 21/32	*	1.55	2 7/8	6	3 13/16	*	1.68	3 1/4
8	6	4 1/16	1/8	1.07		6	4 3/16	*	1.32	1 1/2	6	4 11/32	*	1.44	1 27/32	6	4 15/32	*	1.57	2 3/16
9	6	4 3/16	*	1.32	1 1/2	6	4 11/32	*	1.44	1 27/32	6	4 15/32	*	1.57	2 3/16	6	4 19/32	*	1.69	2 17/32
10	8	3 5/8	9/32	1.33		8	3 23/32	3/16	1.33		8	3 13/16	3/32	1.33		8	3 15/16	*	1.58	1 1/2
11	8	3 23/32	3/16	1.33		8	3 13/16	3/32	1.33		8	3 15/16	*	1.58	1 1/2	8	4 1/32	*	1.71	1 27/32
12	8	4 7/32	15/32	1.60		8	4 5/16	3/8	1.60		8	4 13/32	9/32	1.60		8	4 1/2	3/16	1.60	
14	8	4 23/32	25/32	1.86		8	4 13/16	21/32	1.86		8	4 29/32	9/16	1.86		8	5	15/32	1.86	
15	8	4 13/16	21/32	1.86		8	4 29/32	9/16	1.86		8	5	15/32	1.86		8	5 3/32	3/8	1.86	
16	8	5 5/16	31/32	2.12		8	5 13/32	7/8	2.12		8	5 1/2	25/32	2.12		8	5 19/32	21/32	2.12	
17	8	5 13/32	7/8	2.12		8	5 1/2	25/32	2.12		8	5 19/32	21/32	2.12		8	5 11/16	9/16	2.12	
18	8	5 29/32	1 5/32	2.38		8	6	1 1/16	2.38		8	6 3/32	31/32	2.38		8	6 3/16	7/8	2.38	
19	8	6	1 1/16	2.38		8	6 3/32	31/32	2.38		8	6 3/16	7/8	2.38		10	5 3/16	15/32	2.39	
20	10	5 3/16	1 3/32	2.65		10	5 1/4	1	2.65		10	5 11/32	15/16	2.65		10	5 13/32	27/32	2.65	
21	10	5 1/4	1	2.65		10	5 11/32	15/16	2.65		10	5 13/32	27/32	2.65		10	5 1/2	25/32	2.65	
22	10	5 21/32	1 1/4	2.91		10	5 23/32	1 5/32	2.91		10	5 13/16	1 3/32	2.91		10	5 7/8	1	2.91	
23	10	5 23/32	1 5/32	2.91		10	5 13/16	1 3/32	2.91		10	5 7/8	1	2.91		10	5 31/32	15/16	2.91	
24	10	6 1/8	1 13/32	3.17		10	6 3/16	1 5/16	3.17		10	6 9/32	1 1/4	3.17		10	6 11/32	1 5/32	3.17	

- A = Minimum Number of Miters for 90° Ell, use half for 45° Ell
- B = Miter Base Dimension
- C = Miter Top Dimension (* Denotes Negative Radius, See Column E)
- D = Lineal Feet of Pipe Covering for One Fitting Cover
(Based on alternating cuts and allowing for saw kerf and waste)
- E = Tangent Length for Negative Radius Fittings (Figure 2.2)¹

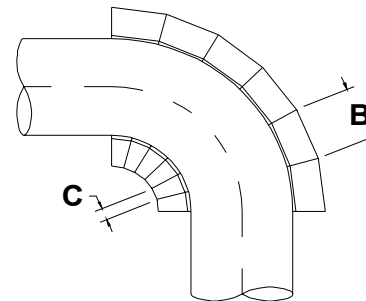

Figure 2.1 Regular Short Radius Ell

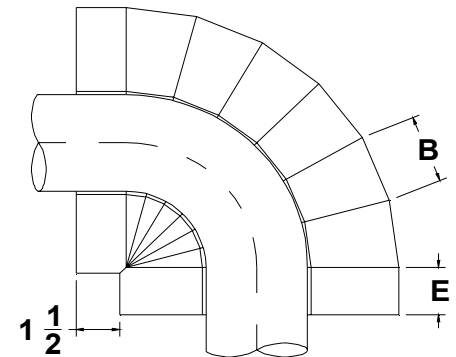

Figure 2.2 Negative Radius Ell

¹ - Mitered Negative Radius Fitting Covers create a 'humped' phenomenon in the throat of the fitting. This 'hump' must be rasped down to ensure proper fit with metal elbow covers.

ASTM C-450

Short Radius Ells - Recommended Dimensional Standards

Insulation Thickness

Pipe Size	5"					5 1/2"					6"				
	A	B	C	D	E	A	B	C	D	E	A	B	C	D	E
1	4	2 23/32	*	1.60	4 7/8	4	2 29/32	*	1.73	5 7/32	6	2 3/32	*	1.89	5 11/16
1 1/4	4	2 13/16	*	1.57	4 11/16	4	3 1/32	*	1.70	5 1/32	6	2 5/32	*	1.86	5 1/2
1 1/2	4	3 1/8	*	1.67	4 7/8	6	2 7/32	*	1.83	5 11/32	6	2 11/32	*	1.95	5 11/16
2	6	2 3/16	*	1.62	4 9/16	6	2 11/32	*	1.77	5	6	2 1/2	*	1.90	5 11/32
2 1/2	6	2 1/2	*	1.71	4 5/8	6	2 5/8	*	1.84	5	6	2 3/4	*	1.96	5 11/32
3	6	2 5/8	*	1.65	4 9/32	6	2 3/4	*	1.78	4 5/8	6	2 7/8	*	1.90	5
3 1/2	6	2 7/8	*	1.72	4 9/32	6	3	*	1.84	4 5/8	6	3 5/32	*	1.97	5
4	6	3	*	1.66	3 15/16	6	3 5/32	*	1.79	4 9/32	6	3 9/32	*	1.91	4 5/8
4 1/2	6	3 5/32	*	1.79	4 9/32	6	3 9/32	*	1.91	4 5/8	6	3 13/32	*	2.03	5
5	6	3 13/32	*	1.67	3 19/32	6	3 17/32	*	1.79	3 15/16	6	3 21/32	*	1.92	4 9/32
6	6	3 13/16	*	1.68	3 1/4	6	3 15/16	*	1.80	3 19/32	6	4 1/16	*	1.93	3 15/16
7	6	3 15/16	*	1.80	3 19/32	6	4 1/16	*	1.93	3 15/16	6	4 3/16	*	2.05	4 9/32
8	6	4 19/32	*	1.69	2 17/32	6	4 23/32	*	1.82	2 7/8	8	3 5/8	*	1.94	3 1/4
9	6	4 23/32	*	1.82	2 7/8	8	3 5/8	*	1.94	3 1/4	8	3 23/32	*	2.07	3 19/32
10	8	4 1/32	*	1.71	1 27/32	8	4 1/8	*	1.83	2 3/16	8	4 7/32	*	1.96	2 17/32
11	8	4 1/8	*	1.83	2 3/16	8	4 7/32	*	1.96	2 17/32	8	4 5/16	*	2.08	2 29/32
12	8	4 5/8	3/32	1.60		8	4 23/32	*	1.85	1 1/2	8	4 13/16	*	1.97	1 27/32
14	8	5 3/32	3/8	1.86		8	5 7/32	9/32	1.86		8	5 5/16	3/16	1.86	
15	8	5 7/32	9/32	1.86		8	5 5/16	3/16	1.86		8	5 13/32	3/32	1.86	
16	8	5 11/16	9/16	2.12		8	5 25/32	15/32	2.12		8	5 29/32	3/8	2.12	
17	8	5 25/32	15/32	2.12		8	5 29/32	3/8	2.12		8	6	9/32	2.12	
18	8	6 9/32	25/32	2.38		10	5 3/32	17/32	2.39		10	5 3/16	15/32	2.39	
19	10	5 3/32	17/32	2.39		10	5 3/16	15/32	2.39		10	5 1/4	3/8	2.39	
20	10	5 1/2	25/32	2.65		10	5 9/16	11/16	2.65		10	5 21/32	5/8	2.65	
21	10	5 9/16	11/16	2.65		10	5 21/32	5/8	2.65		10	5 23/32	17/32	2.65	
22	10	5 31/32	15/16	2.91		10	6 1/32	27/32	2.91		10	6 1/8	25/32	2.91	
23	10	6 1/32	27/32	2.91		10	6 1/8	25/32	2.91		10	6 3/16	11/16	2.91	
24	10	6 7/16	1 3/32	3.17		10	6 17/32	1	3.17		10	6 19/32	15/16	3.17	

- A = Minimum Number of Miters for 90° Ell, use half for 45° Ell
- B = Miter Base Dimension
- C = Miter Top Dimension (* Denotes Negative Radius, See Column E)
- D = Lineal Feet of Pipe Covering for One Fitting Cover
(Based on alternating cuts and allowing for saw kerf and waste)
- E = Tangent Length for Negative Radius Fittings (Figure 2.2)¹

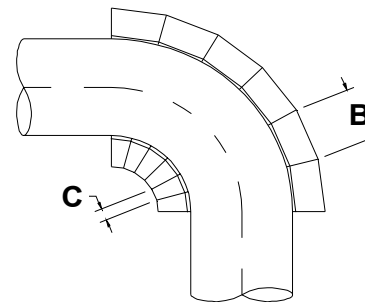

Figure 2.1 Regular Short Radius Ell

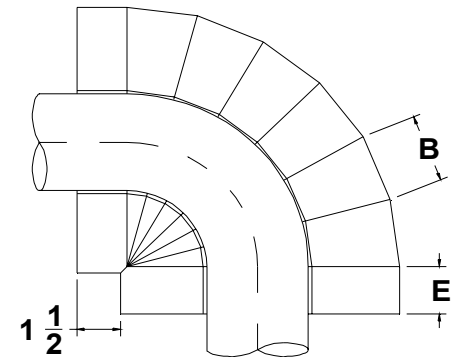

Figure 2.2 Negative Radius Ell

¹ - Mitered Negative Radius Fitting Covers create a 'humped' phenomenon in the throat of the fitting. This 'hump' must be rasped down to ensure proper fit with metal elbow covers.